



Owner's Guide and Installation Manual

PELLA® EXPRESS INSTALL® STORM DOOR MODELS

NOTE TO THE INSTALLER: This Owner's Guide and Installation Manual is the property of the homeowner. Please leave it with the homeowner upon completion of the installation.



Recommended Tools

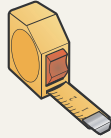

Tape Measure



Power Drill



Pencil

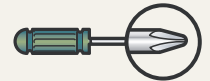

Phillips Screwdriver #2

For safety reasons, the assistance of a second person is recommended when handling the door.

Read the legend below in order to easily follow along and install your storm door.
For reference, the storm door assembly is illustrated on page 2.

Legend

1 • **2** • **3** • • • Follow the steps in order.



Steps in **BLUE** apply to **LEFT HINGE** configurations **ONLY**.
(Hinge side will be determined in a later step.)



Steps in **GREEN** apply to **RIGHT HINGE** configurations **ONLY**.
(Hinge side will be determined in a later step.)

To order replacement parts, call
888-646-5354

or visit us at

www.pella.com

Please have your registration number
ready when you contact us.

TROUBLE SHOOTING GUIDE
is located at the end of this manual.

Lay door flat.
Before discarding the carton, make sure **ALL** parts are
accounted for.

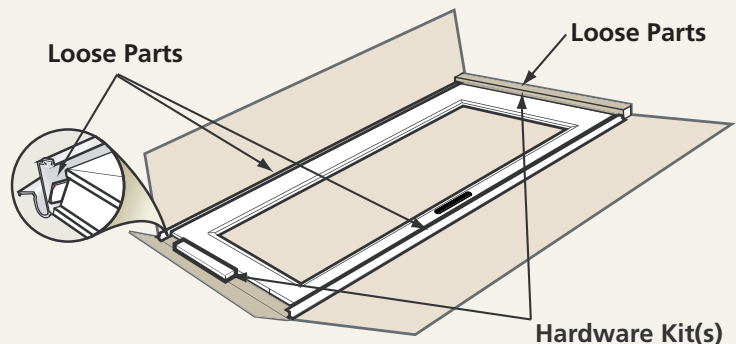

The carton material is recyclable

Storm Door Components

NOTE: Actual door styles may vary from illustrations, however, the installation steps will be the same.

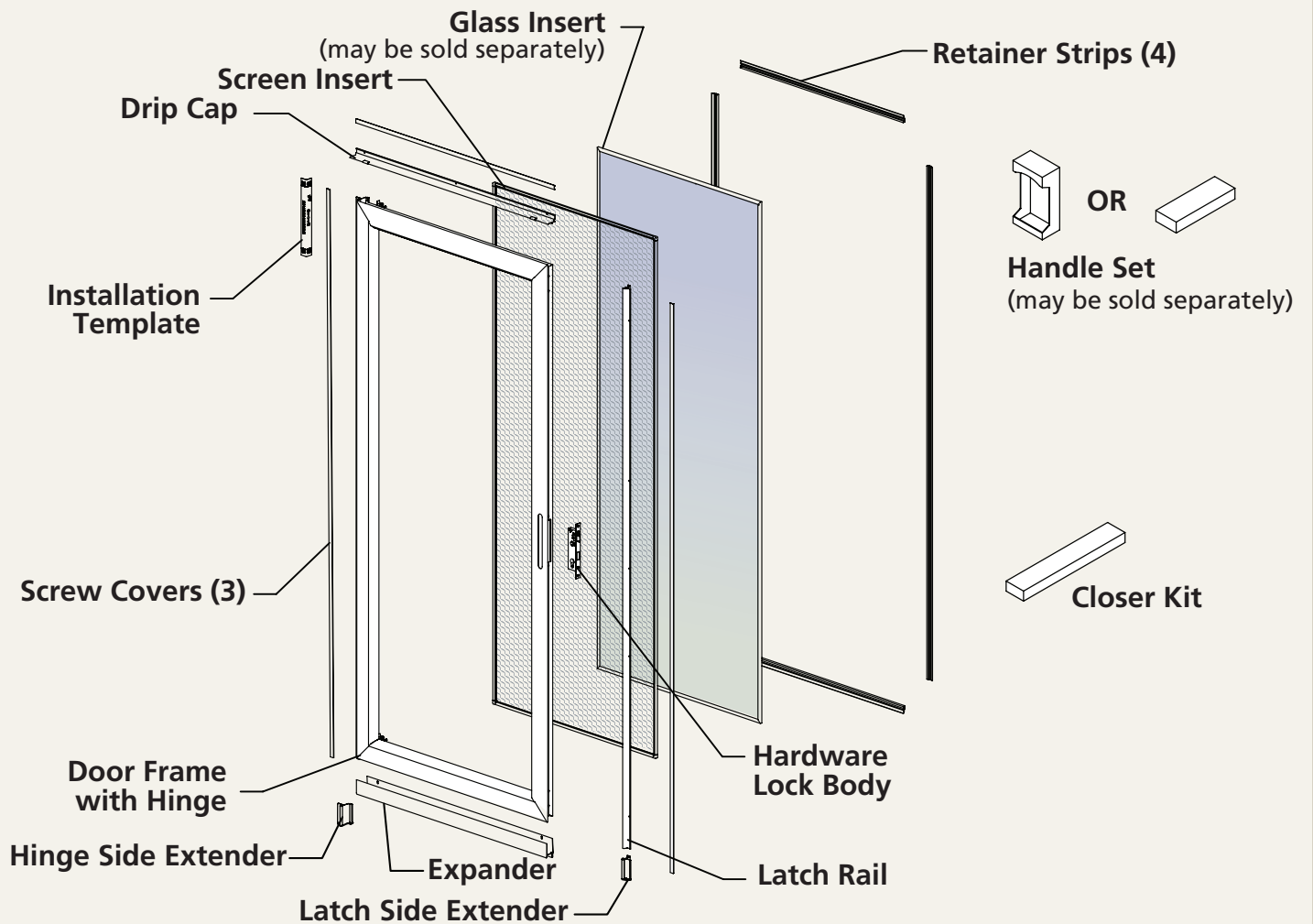
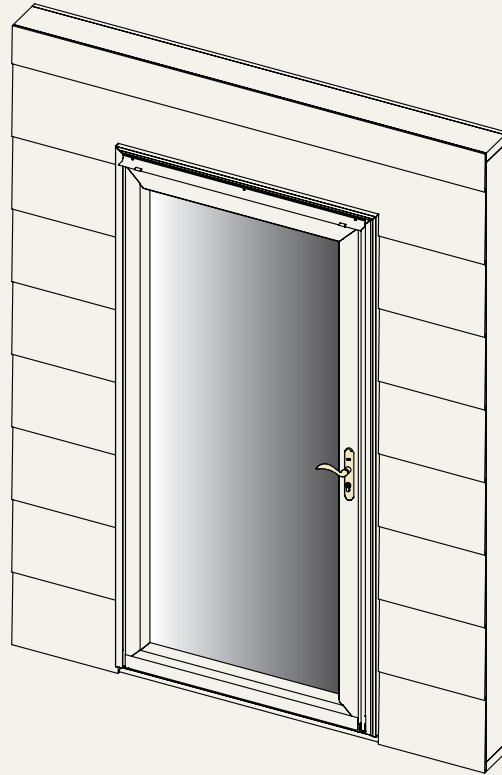

Before you begin

a Determine the hinge side of your storm door.

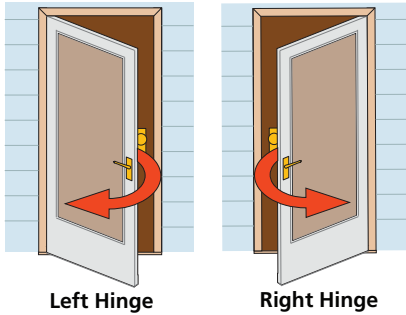

b 1-in wide x 1-in deep mounting surface is required. Hinge-side shimming may be required to fit existing opening.

Nominal Door Sizes	Opening Width (No shim required)	Opening Width (Shim required)	Shim to this Opening Width	Opening Height
36-in x 81-in	35-7/8 in – 36-in	36-1/16-in – 36-3/8-in	35-7/8-in – 36-in	80-in to 81-in
34-in x 81-in	33-7/8 in – 34-in	34-1/16-in – 34-3/8-in	33-7/8-in – 34-in	
32-in x 81-in	31-7/8 in – 32-in	32-1/16-in – 32-3/8-in	31-7/8-in – 32-in	
30-in x 81-in	29-7/8 in – 30-in	30-1/16-in – 30-3/8-in	29-7/8-in – 30-in	

c Shim on your hinge side, as determined above. Shim may be one long piece or small 8-in to 12-in sections. Use an appropriate shim thickness to reduce the opening as noted in the chart. Household shim materials may include paint stir sticks or wooden yardsticks.

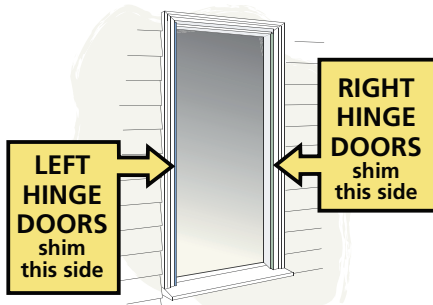

Top View

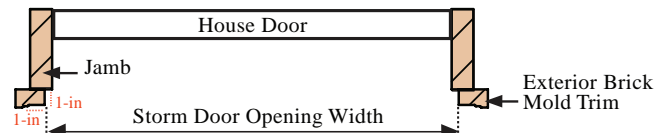

d Check for existing door hardware interference. If storm door hardware will interfere with your house door hardware, we recommend placing the storm door hinge on the opposite side. Nail shim in place.

e Verify house door trim is securely attached and square. If you removed an old storm door, you may wish to fill and paint any existing holes before proceeding.

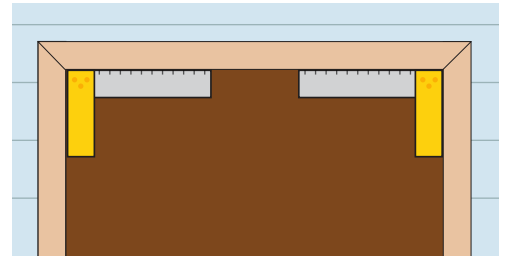
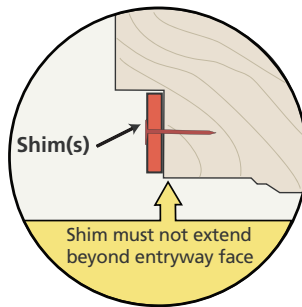

- 1** Turn door so the interior faces up. Remove any shipping clips or retainer strips. Remove screen. Set aside lock-body and loose parts.

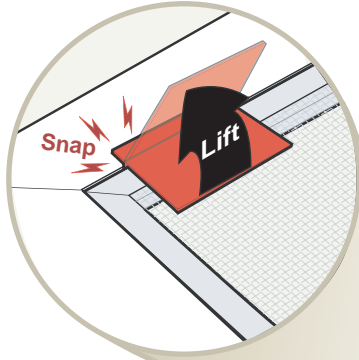

Remember this is the **INTERIOR SIDE** of the door

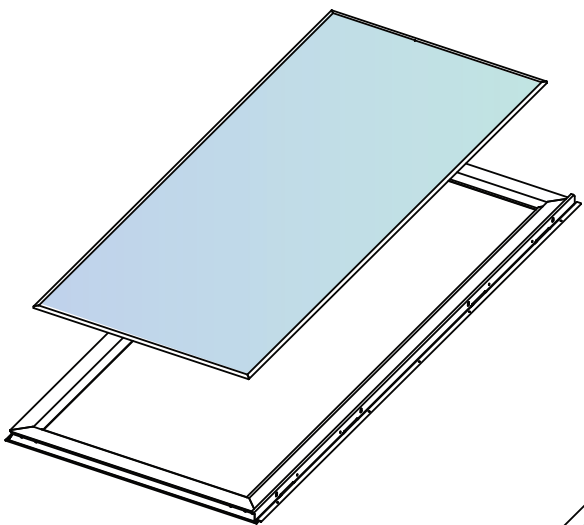
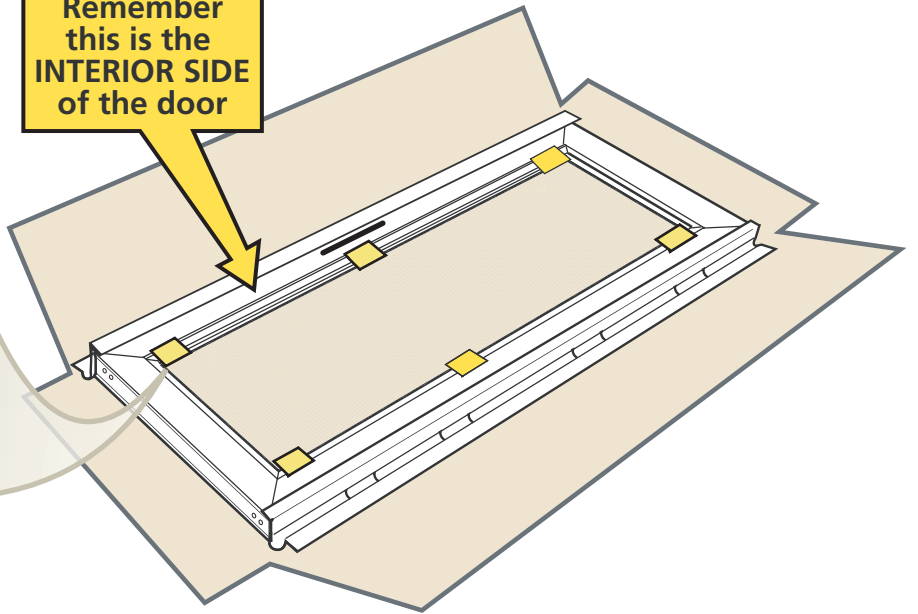

- 2** Set glass insert into opening with "Exterior Side" sticker facing down.

Install Both Top and Bottom

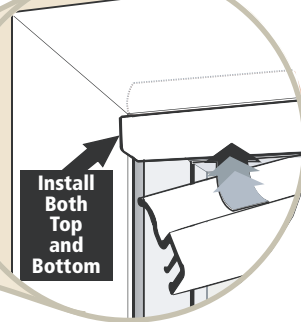

Install Both Left and Right

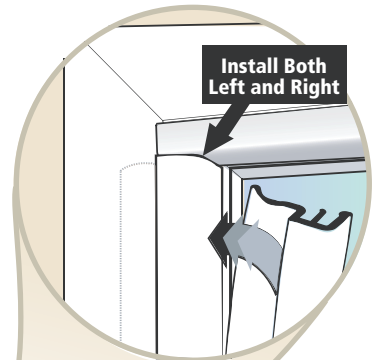

- 3** Install the short retainer strips into the top and bottom channels.

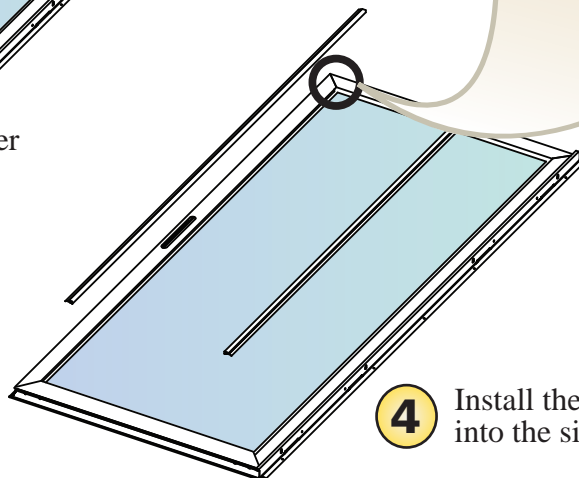

- 4** Install the long retainers into the side channels.

- 5** Locate the rail extenders. Slide the rail extender into the bottom of the hinge rail. For LEFT HINGE installation, use the rail extender marked with an “L”. For RIGHT HINGE installation, use the rail extender marked with an “R”.

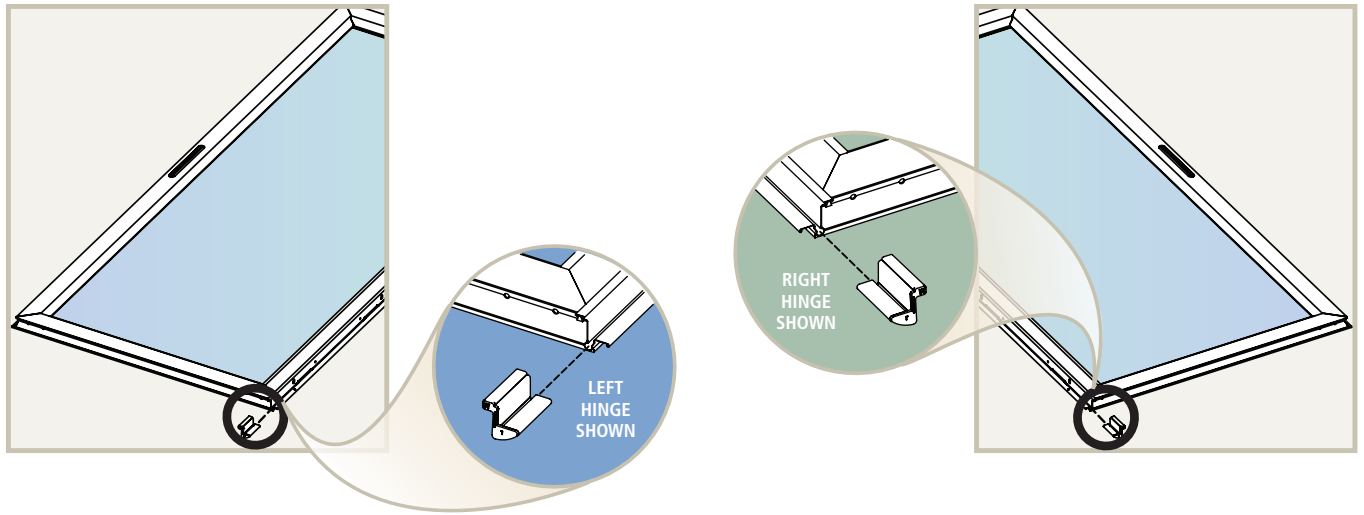

- 6** Slide the bottom expander onto the bottom of the door, with the slots to the interior. Do NOT secure with screws at this time. Trim the expander sweep length leaving 1/8" past the expander edges.

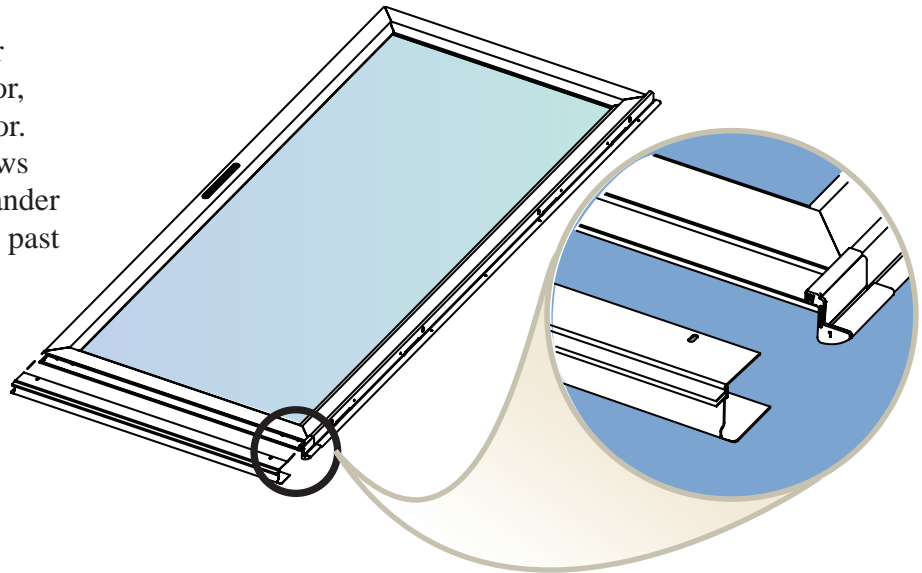

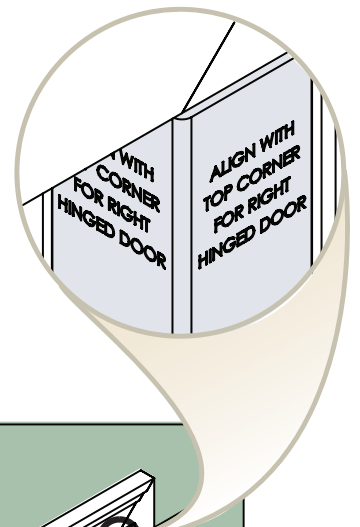
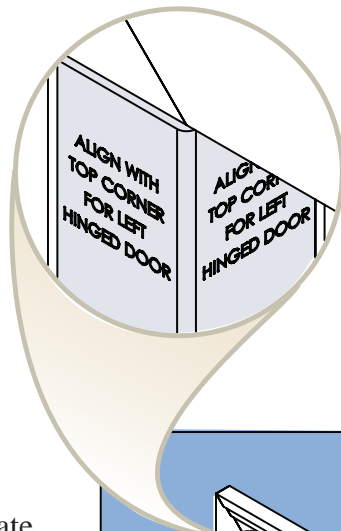

- 7** Locate the screw template in Bag A of the Closer Kit. Position it with the proper end UP based on your hinge position. Place the template tight against the hinge side of the door frame, and slide to the top.

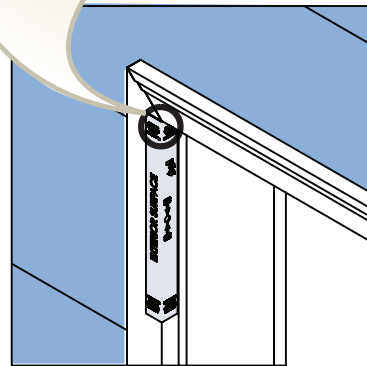

Left Hinge

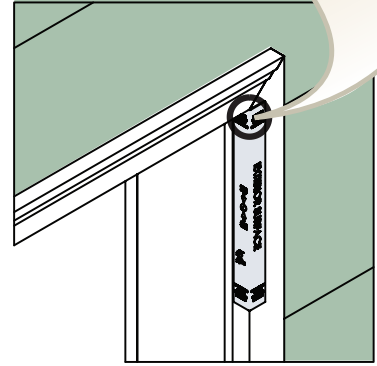

Right Hinge

- 8** Holding the template in place, install the placeholder screw into the center of hole. Do not tighten all of the way. Leave 1/8-in of the screw exposed. Remove and discard template.

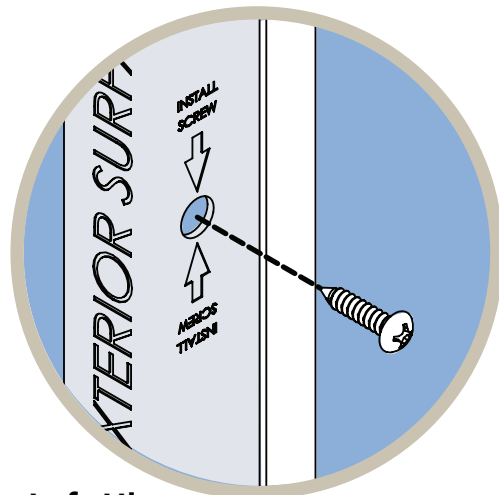

Left Hinge

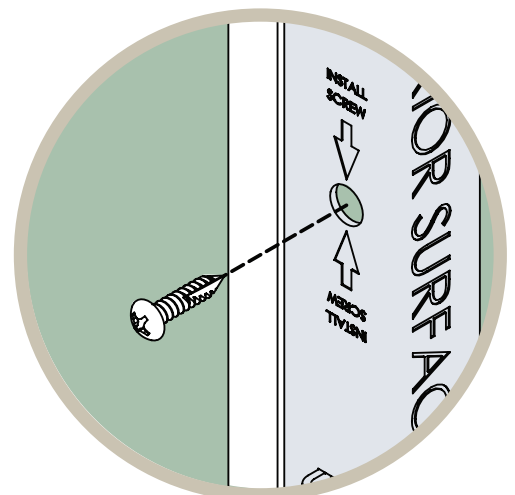

Right Hinge

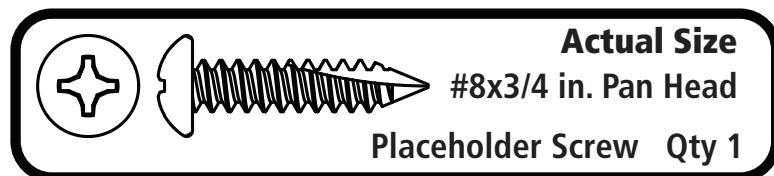

- 9** Hang storm door onto door frame using the placeholder screw. The door will settle approximately 1/16-in. Tighten screw while pushing top of hinge rail tight against the door frame.

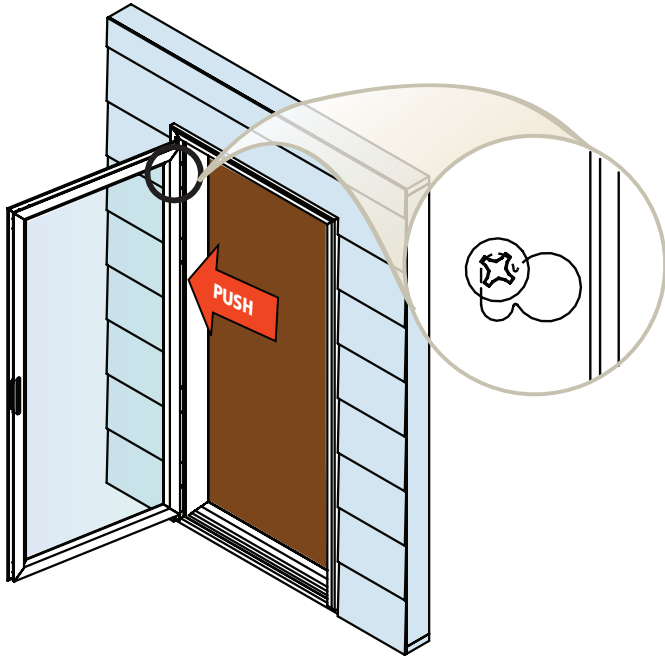

- 10** Install door installation screw from Bag B in the lowest hole on the hinge rail, and secure door in opening.

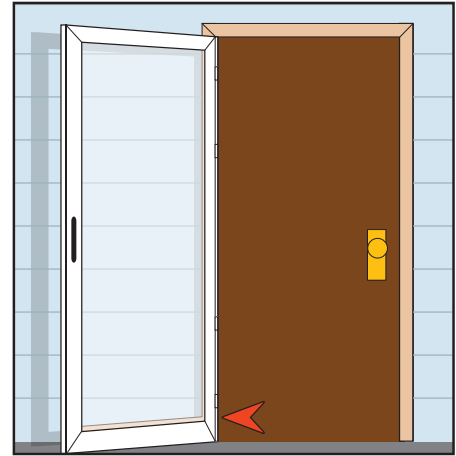

Qty. 1 Installation Screw
#8 x 3/4-in Pan Head

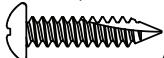

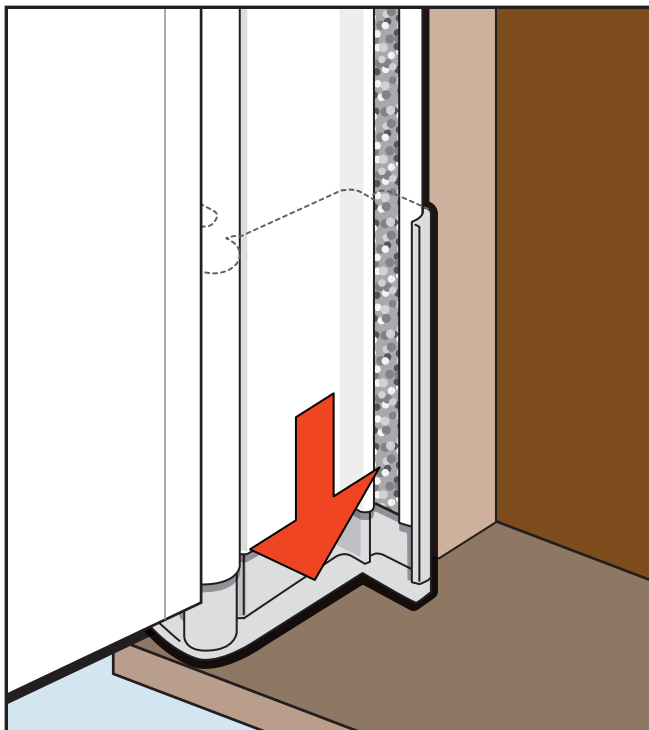

Actual Size

- 11** Slide rail extender to sill. Loosen door installation screw if needed and then retighten.

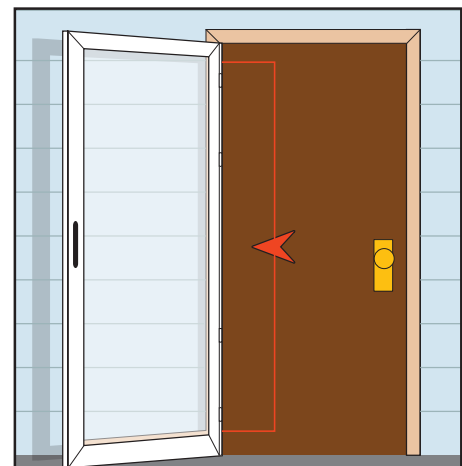

- 12** Install door installation screws from Bag B on the inner side of hinge rail in remaining six locations.



Qty. 6 Installation Screw
#8 x 3/4-in Pan Head

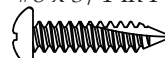

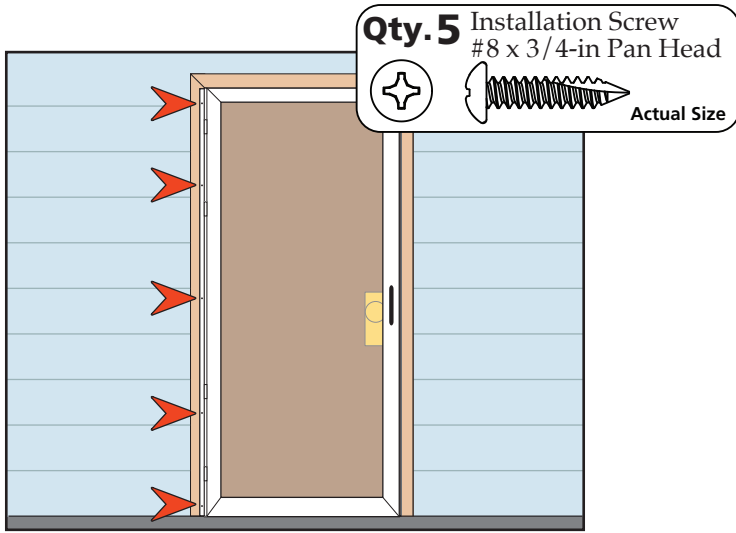

Actual Size

- 13** Push door tight against door frame. Install door installation screws from Bag B on the outer face of the hinge rail. Do not over tighten screws.

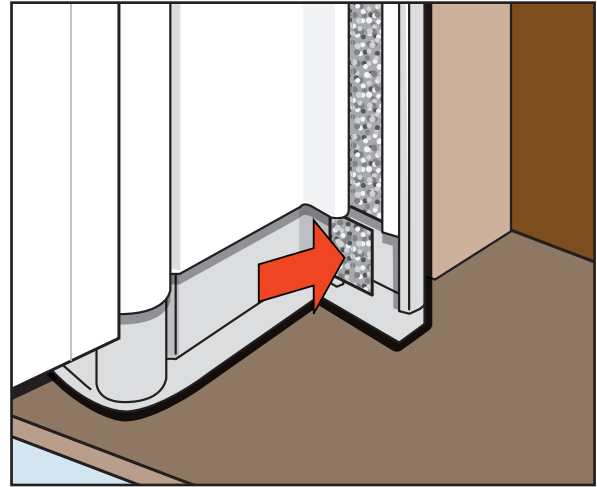

- 14** Cut extender weather stripping to length, remove adhesive backing and install.



- 15** Rest the drip cap on top of the door, using spacers for alignment. Close door and align the end of the drip cap with the outside edge of the hinge rail.

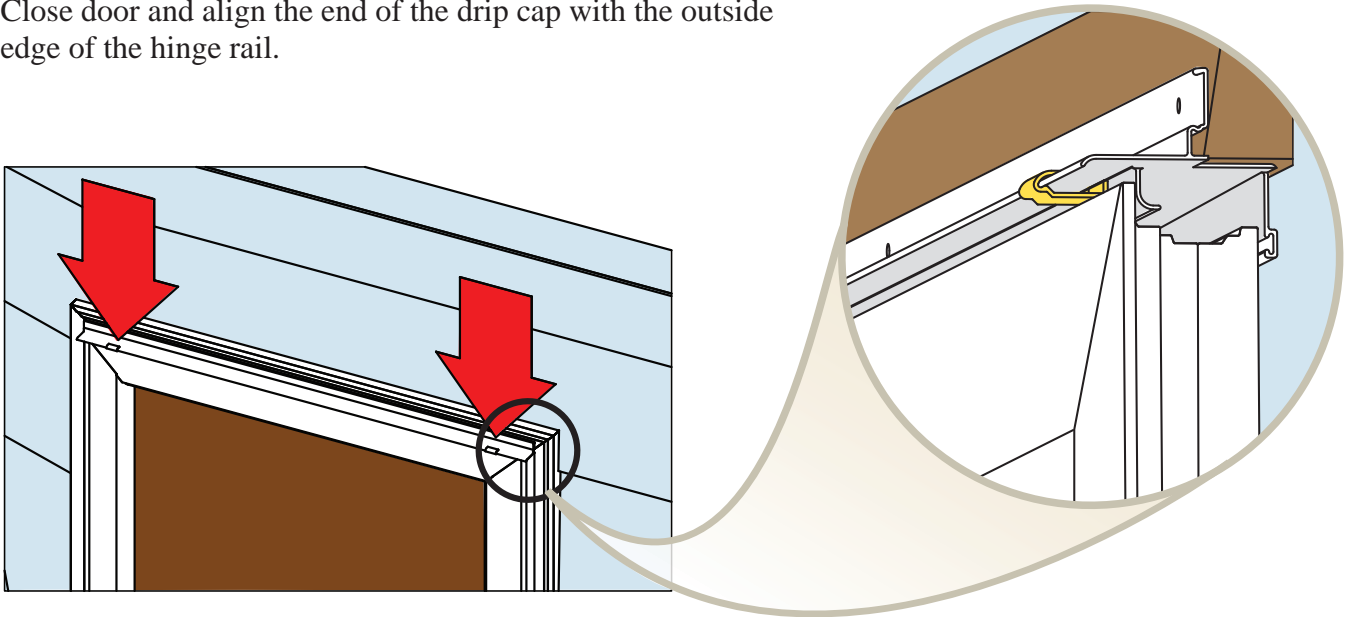

- 16** Secure drip cap with installation screws from Bag B. Remove and discard the spacer clips. Caulk along top edge of drip cap if desired.

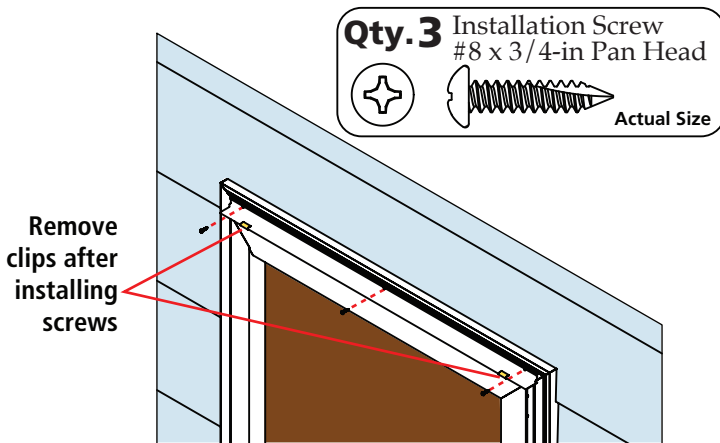

- 17** Slide the remaining rail extender onto the bottom of the latch rail. For LEFT HINGE installation, use the rail extender marked with an “R”. For RIGHT HINGE installation, use the rail extender marked with an “L”.

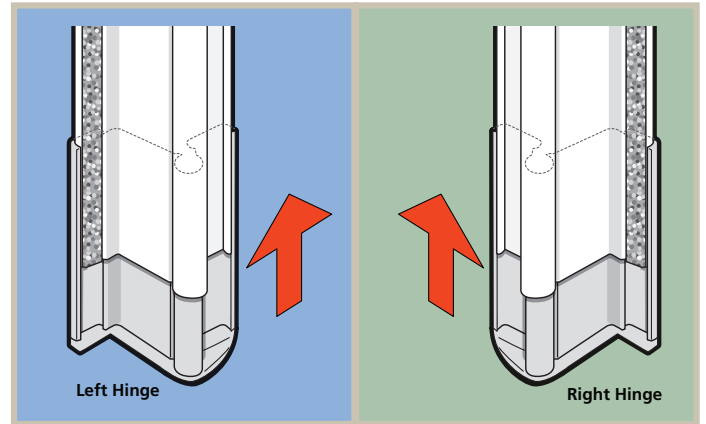

- 18** Place latch rail tight against the drip cap.

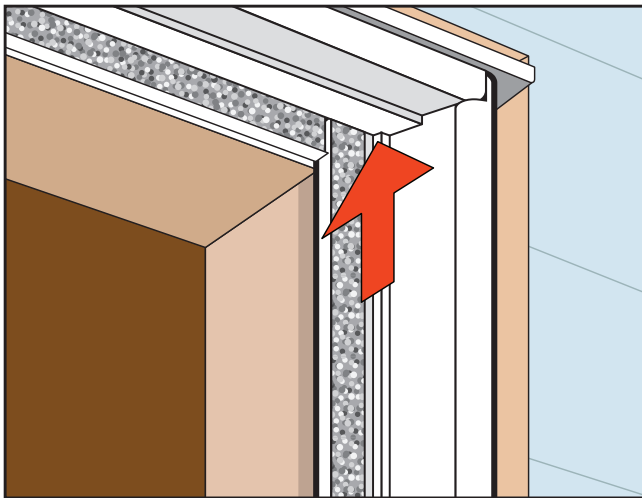

- 19** Verify that the door closes freely without hitting the latch rail. Align outside edge of the latch rail with outside edge of the drip cap.

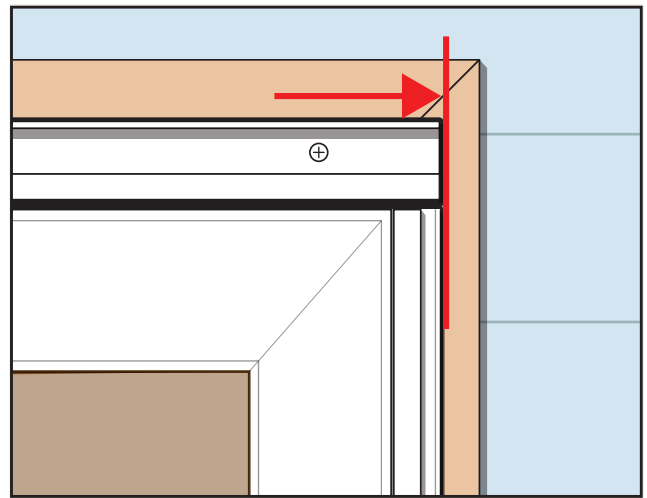

20 Fasten the latch rail with door installation screws from Bag B.

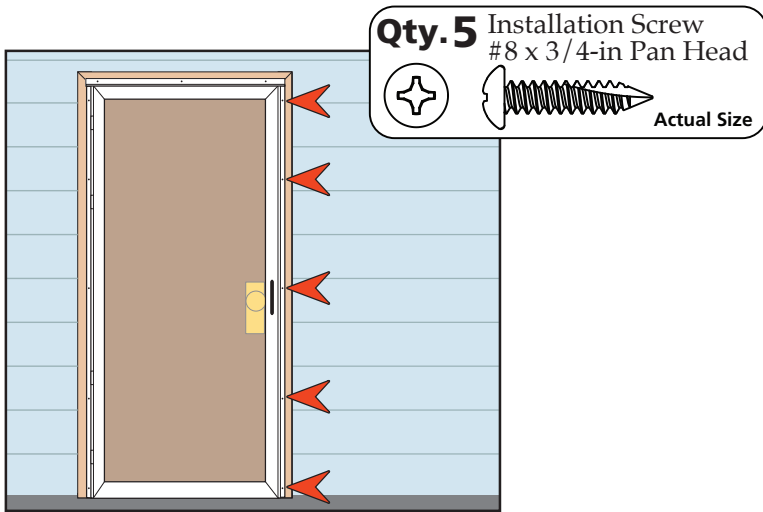

21 Slide rail extender to the sill.

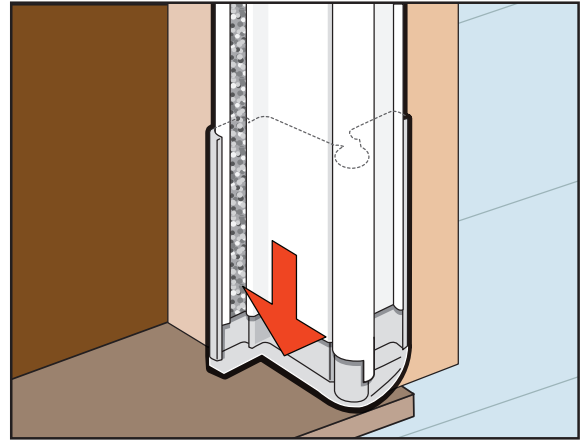

22 Cut extender weather stripping to length, remove adhesive backing and install.

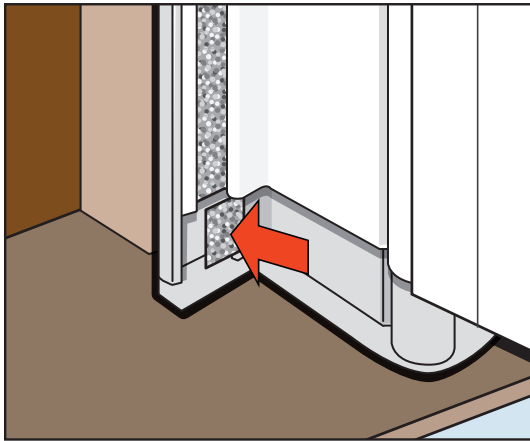

23 Following the instructions in the handle kit, install the lock body and handle.

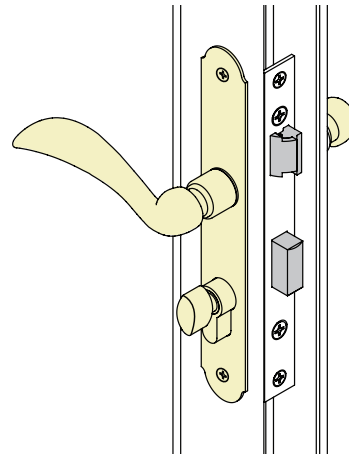

Handle Kit may be sold separately.

24 Install screw cover strips (1 horizontal, 2 vertical).

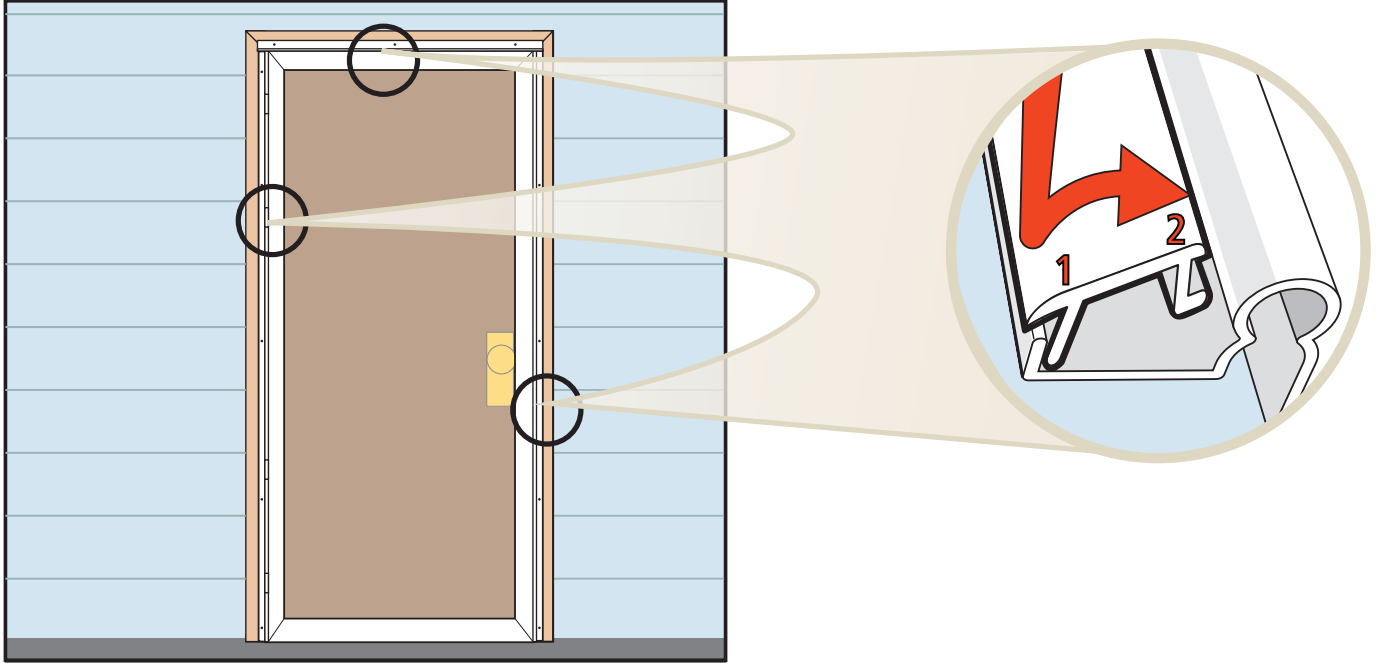

25 Close the door. Adjust the bottom expander to lightly contact the sill. Install expander screws from Bag D.

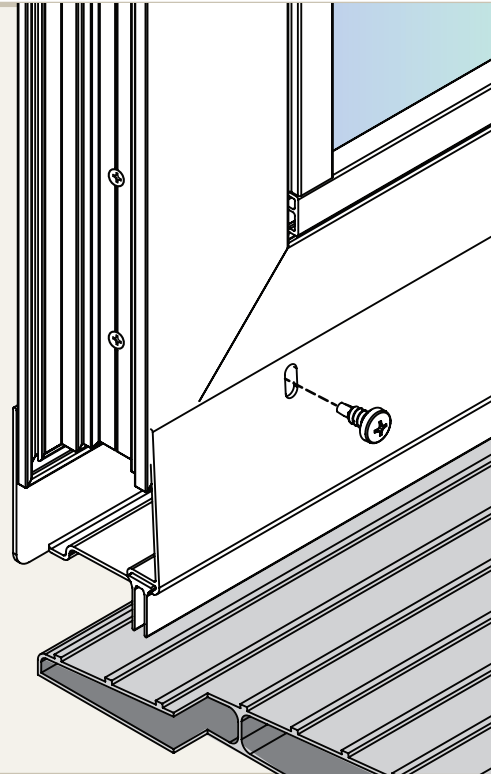
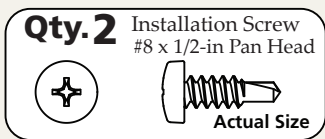

26 Locate the two closer bases in the closer kit. Remove and discard the hole plugs.

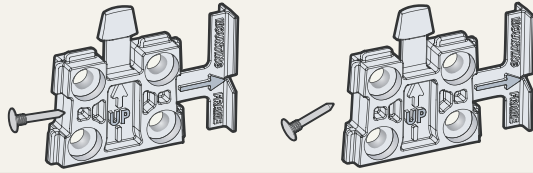

27 Determine which side to install the closers, based on your hinge installation.

LEFT HINGE Install Closers on this side
RIGHT HINGE Install Closers on this side

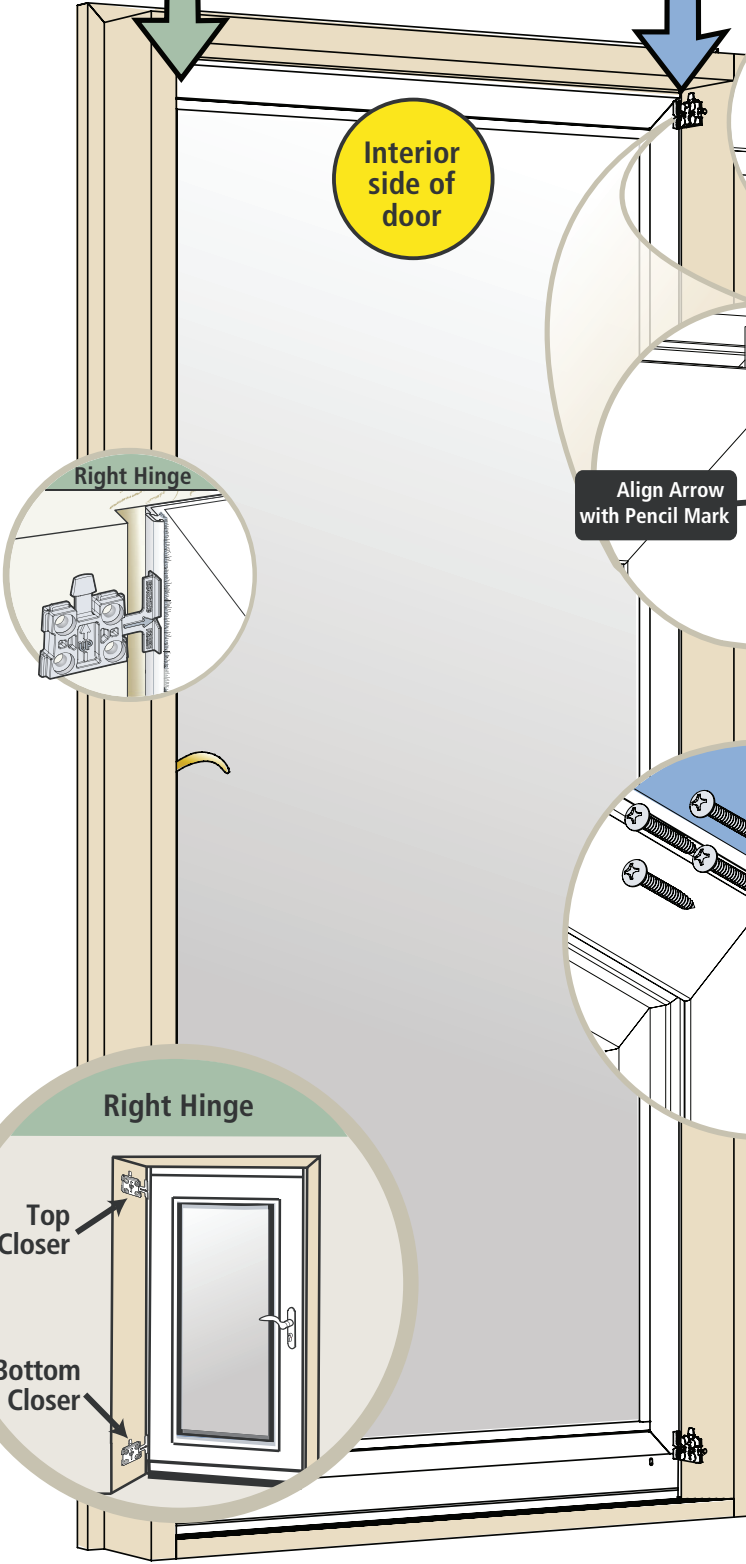

Interior side of door

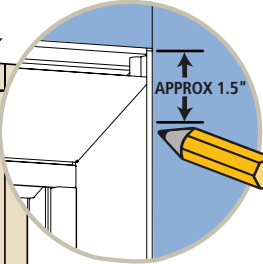

28 From inside your house, measure 1-1/2-in down from the top of the hinge mounting rail and mark with a pencil.

29 Measure 1-1/2-in up from the bottom of the hinge mounting rail and mark with pencil.

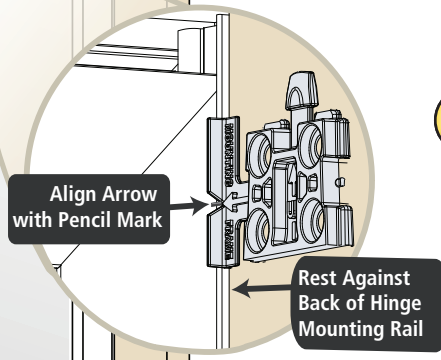
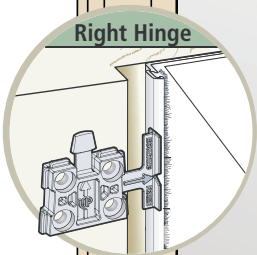

30 Align the arrow on the closer base with the mark you made, and rest the base against the back of the hinge mounting rail.

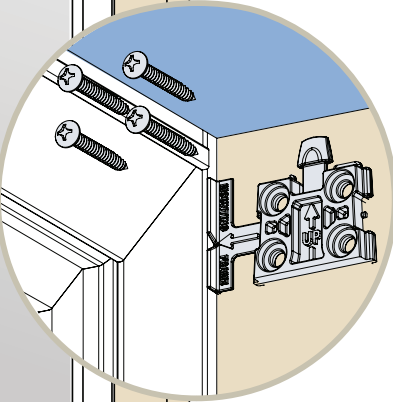

31 Secure base with four closer base screws. Repeat for second closer base, aligning base arrow with your mark.

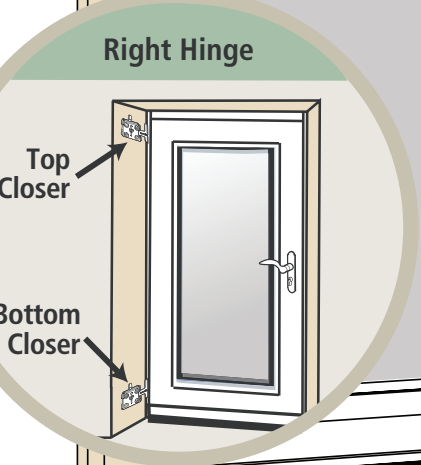
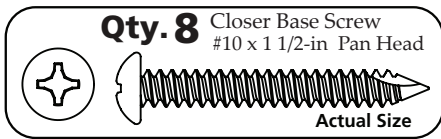

32 Break off alignment tabs.

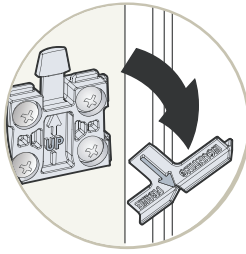

33 Locate the top and bottom closers.

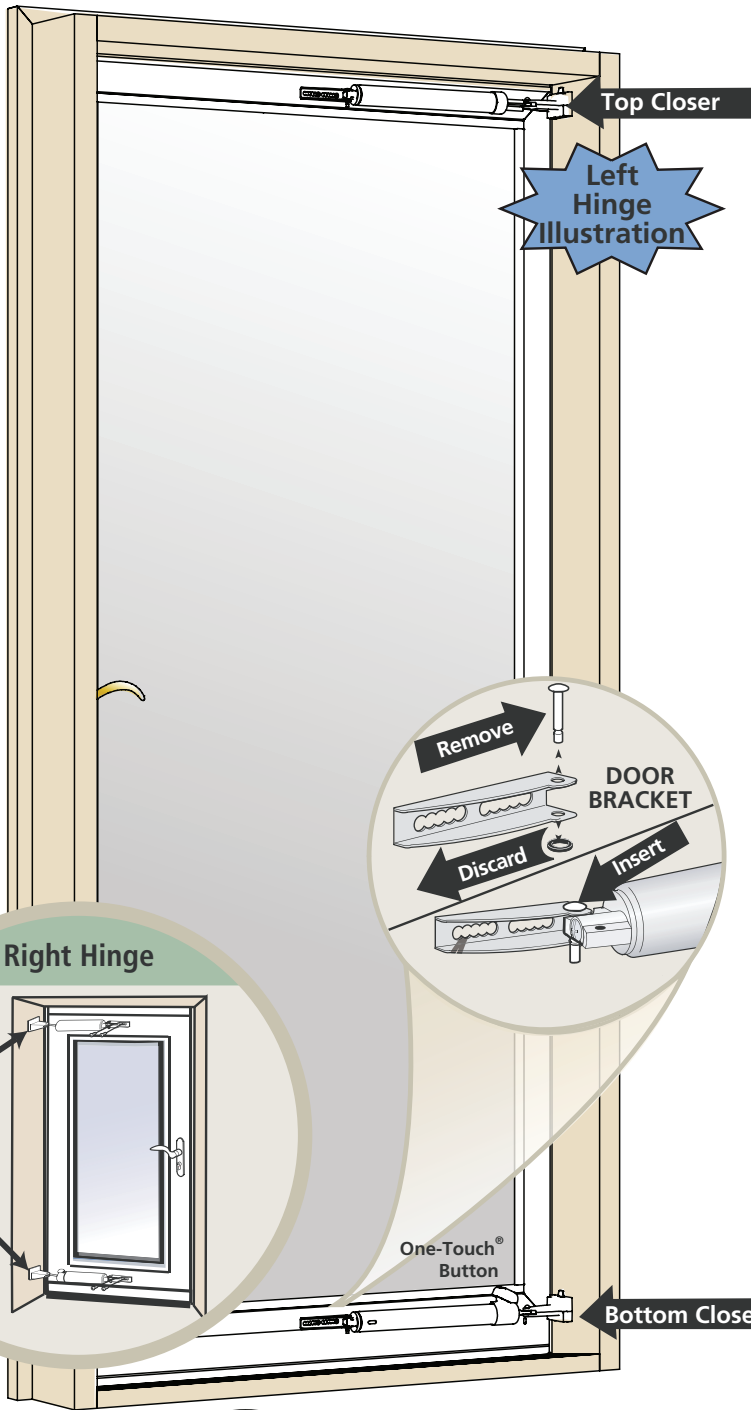
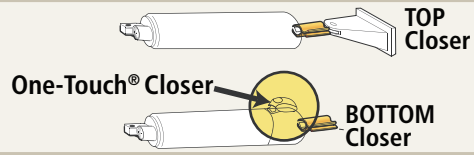

34 Attach jamb bracket to bottom closer with the short pin, positioning One-Touch® button facing up as shown. Leave yellow clip in place.

35 Slide top and bottom closers onto their bases.

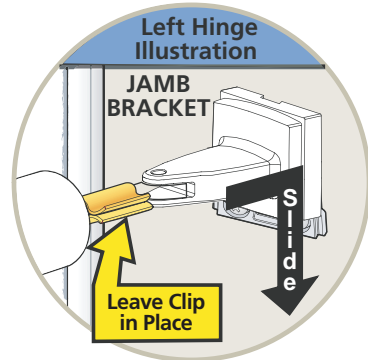

36 Attach door bracket to closer assembly with the long pin.

37 Close door. Secure the door bracket with door bracket screws.

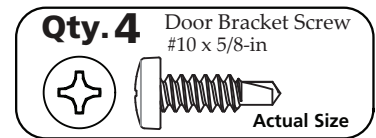
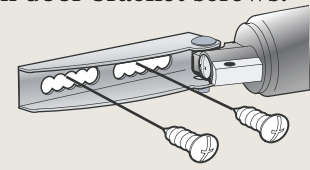

38 Discard clips (top and bottom).

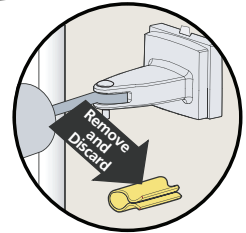

39 Adjust closer speed with adjustment screw.

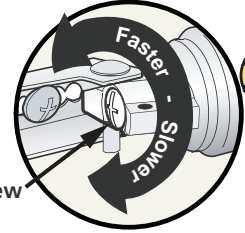

40 TO USE: Open the door, then tap the button.
TO CLOSE: Nudge the door open slightly.

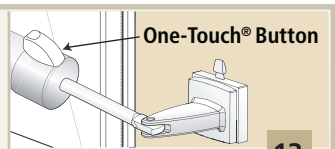

Care and Maintenance

Door Cleaning

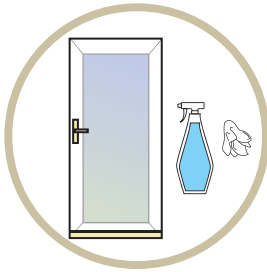

Use a soft cloth with any household grease-cutting cleaner to clean the door.

PLEASE NOTE: Thin marks on the painted surfaces of the door can be removed using turpentine and light rubbing with a clean cloth.

IMPORTANT: DO NOT use brass polish or steel wool on the bottom expander. Use a household grease-cutting cleaner or a mild soap and water solution.

PLAIN GLASS

DO NOT use an ammonia-based cleaner for the first cleaning of the glass.

Glass Cleaning

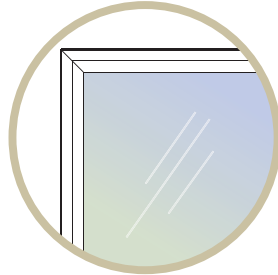

FIRST CLEANING: Use a mixture of one part vinegar with four parts water to remove the protective coating (for shipping purposes) from the glass.

ROUTINE CLEANING: Use any household glass cleaner.

LOW-E GLASS

RECOMMENDED ROUTINE CLEANING: Clean the glass with plain water, using a clean soft sponge or lint-free cloth to remove as much surface grime from the glass as possible. If needed, wash the surface of the glass again with a solution of 80% water and 20% vinegar with a clean soft lint-free cloth. Dry with a new soft cloth. Cleaning may cause streaks when dried if the glass is exceptionally dirty. In this case repeat cleaning.

NOTE:

- Care must be exercised when using rubber squeegees on the coated surface, as they can leave streaks that are hard to remove if they are used incorrectly or are in poor condition.
- Never use ANY type of scraper or abrasive cleaner on the coated surface. Particles from these materials can be deposited on the coated surface and are very difficult to remove.
- For unusually hard to remove spots such as crayon or grease, isopropyl alcohol, GooGone® or GoofOff® may be used. After spot cleaning, the full glass surface should be cleaned following the recommended routine cleaning instructions.

Handle Cleaning

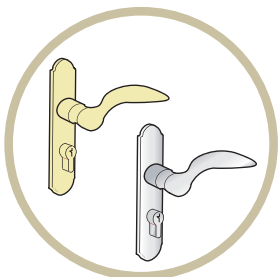

BRASS & NICKEL FINISHES

Routine Cleaning: Use a soft cloth with a mild soap and water solution to clean the surfaces. Apply a high quality, non-abrasive automobile wax to polish.

Note: NEVER use ammonia-based cleaners on brass or other metallic finish handles.

If your Pella® door includes a solid brass handle, the brass is polished and sealed with a clear coating by the manufacturer. Should the finish be accidentally damaged by an abrasive or sharp object, it will succumb to a natural oxidation process that occurs when the elements contact unprotected brass. Brass has an enduring quality, in that it can be refurbished to its original polished finish again and again by using a quality brass polish and a soft cloth. Do not clean the bottom expander in this manner - see door cleaning above.

1. Remove the hardware from the door so the finish of the door will not be affected. See the hardware instructions for removal. **NOTE:** you may be able to leave the hardware in place on the door when polishing the handle only – make certain to completely mask off all areas around the handle before starting. If polishing the key cylinder, protect the internal mechanism by covering the opening with tape.
2. Use a quality brass polish or cleaner to clean the brass - follow the product's directions and cautions. Note: Firm rubbing may be necessary to loosen the coating on the brass.
3. Reseal the brass per instructions below.
 - a. Use the properties from the brass polish you used to clean the brass. (Easiest method, but requires more frequent polishing.)
 - b. Apply a high quality, non-abrasive, polymer-based automobile wax to seal the surface.
 - c. Apply a new clear coat with a clear lacquer spray - follow the product's directions. (Most difficult, but lasts the longest.)

PLEASE NOTE: If you removed the hardware from the door, lubricate any internal workings with a spray lubricant. Re-install the hardware on the door. See the hardware instructions for installation.

Troubleshooting Guide

If you have a question that you do not see listed here, or have not been able to resolve through your Pella® Owner's Manual and Installation Guide, call one of our customer service representatives toll-free at 1-800-374-4758.

Common Questions	Probable Causes	Suggested Solutions
Door does not open or close properly.	Entryway framing is out of square/plumb or frame is warped	1. Verify the entryway framing and shim as necessary. [See Page 2]
	Closer(s) out of position or adjustment.	1. Remove the adjustment screw from the closer(s), cycle the door a few times, then replace the screw. [See Page 10, Step 39] 2. Adjust the position of the closer door bracket until the door operates properly. [see Page 10, Step 37] 3. If switching from glass to screen, vary the closer speed for proper operation. [see page 10, Step 39]
	Bottom Expander is out of position.	1. Verify the expander is centered on the door – adjust if necessary. [See Page 4] 2. Verify the expander is not too low - adjust as necessary. [See Page 8, Step 25] 3. Verify sweep length is no more than 1/8" past expander edges. Trim as necessary.
	Drip Cap is out of position.	1. Verify drip cap is centered and aligned in the opening - adjust as necessary. [See Page 5, Step 12, Page 6, Step 13]
	Hinges are binding	1. Verify mounting frame screws are not over tightened - back off screws slightly. [See Page 6, Step 13] 2. Verify entryway framing is not twisted or warped - shim or modify as necessary. 3. Verify hinge mounting frame is not twisted or bent - replace if necessary.
Handle does not latch properly.	Latch not hitting trim plate	1. Adjust the trim plate until the latch catches. [See separate hardware instruction]
	Closer is out of position	1. See "Closer(s) out of position" in the "Door does not open or close properly" question above.
Water between the storm door and entry door.	Bottom Sweep is making a tight seal against the door sill	1. Open the storm door and notch up to 1/2-in off the ends of the black vinyl sweep.

Pella® Storm Doors Limited Warranty

Congratulations on choosing a Pella storm door to protect and beautify your home. This superior quality door has been designed to give you years of trouble-free service, and you are protected by this limited warranty:

Pella warrants to the ORIGINAL HOMEOWNER PURCHASER of this storm door that it will, without charge to the purchaser, provide parts or exchange, at its option, any door determined to be defective in material or workmanship for 20 years after the purchase date. The purchaser will be responsible for transportation charges. Should the door be determined to be defective in material or workmanship AFTER 20 years from the purchase date, the original purchaser may buy one new Pella storm door at 50% of the then-current manufacturer's suggested list price for as long as the original purchaser owns the home on which the door was installed. The purchase must be made directly from the factory, and all transportation charges are the responsibility of the purchaser.

Should the door be determined to be defective and the purchaser incurs a reinstallation cost within three years of the purchase date, he or she may be reimbursed for these costs up to a maximum of \$25.00, upon furnishing a copy of the invoice for the reinstallation costs.

As a condition of this warranty, it is required that the door be used for residential use only in an owner-occupied home, that it be installed properly as an operating door according to manufacturer's instructions, and that it not be altered in any way. For multi-unit housing applications, ask your dealer for a copy of the appropriate warranty or phone Pella's Customer Service Department at the phone number listed below. This warranty is not transferable.

To make a claim under this warranty, you should:

- a) Call our Customer Service Department at 1-888-646-5354 or write to Pella Warranty Service; 2333 Eastbrook Drive; Brookings, SD 57006 USA.
- b) Furnish the original or a copy of the sales receipt or other documents showing the original purchase date and that you are the original purchaser of this door. Exchange is limited to supplying a replacement door of comparable size, style, and color and does not include any cost of removal or installation except as noted above.

The warranty on the latch set and air closer is one year, and any labor charges are not covered. This warranty excludes all damage to glass and screen. This warranty does not cover problems caused by improper storage, handling, installation, use, modification, or maintenance, by Acts of God or by accidents, including accidental glass breakage. It does not apply to normal wear or discoloration of finish; finish problems caused by mechanical damage or abrasion; normal effects of sun and weather, including acid rain, salt spray, or other corrosive elements; damage caused by severe wind; or damage caused by customer abuse or neglect. Oil-Rubbed Bronze is a living finish that will develop its own unique patina with use and is not covered under the Lifetime Finish Guarantee. Bright Brass, Antique Brass, Brushed Brass and Satin Nickel hardware is guaranteed not to tarnish and carries a lifetime finish warranty for as long as the purchaser owns their home.

THIS WARRANTY EXCLUDES ALL INCIDENTAL AND CONSEQUENTIAL DAMAGES. Nothing in this document shall give rise to or extend the period of any warranties implied under state or provincial law, and no implied warranty shall extend beyond the periods covered by this written warranty. Neither Pella Corporation nor any seller of Pella products will be responsible for incidental or consequential damages which may result from a product defect or malfunction. Some states do not allow the exclusion or limitation of incidental or consequential damages, so the above limitation or exclusion may not apply to you. This warranty gives you specific legal rights, and you may have additional rights which vary from state to state. Effective 7/2006.

© 2015